

80D-9

With Tier4 Final Engine installed

MOVING YOU FURTHER

HYUNDAI HEAVY INDUSTRIES



 **HYUNDAI**
CONSTRUCTION EQUIPMENT AMERICAS, INC.

Some of the photos may include optional equipment.

Your Satisfaction is **Our Priority!**

Hyundai introduces a new line of 9-series 8 ton diesel forklift trucks. The newly designed 4 wheel counterbalance trucks provide every operator comfortable driving, increased productivity and easy maintenance.



New Diesel Forklift with Proven Quality and Advanced Technology

- Maximum performance
 - Spacious operator's cab
 - Load indicator
 - OPSS(Operator Presence Sensing System) for safe operation
 - Easy serviceability
 - Hi-mate (Remote Management System)
-



Some of the photos may include optional equipment.

High Efficiency & Optimal Performance



Some of the photos may include optional equipment.

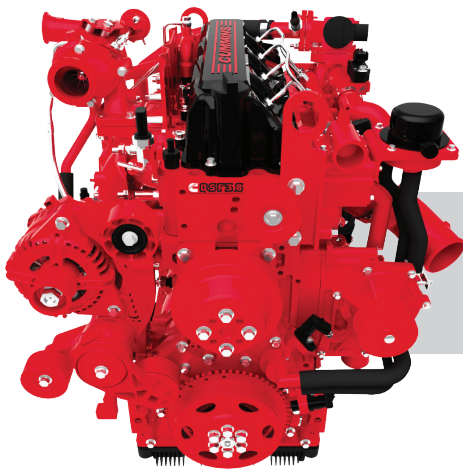

Cummins QSF3.8 Engine

100.6hp/2,200rpm
306lbft/1,600rpm

Powerful Engine

The 4 cylinders turbo-charged engine is built for power, reliability and economy. This engine meets EPA, CARB Tier-4 Final and EU stage IV emission regulation.

High Pressure Common Rail Fuel System(HPCR)

Upgraded HPCR System provides excellent start

Ability & Emission Control

- Combustion efficiency enhancement
- Low noise, Low vibration

Selective Catalytic Reduction(SCR)

- Reduces NOx emissions to near-zero level
- NO DPF

Powerful engine and high technology systems provide you with enhanced performance and highest productivity.

80D-9

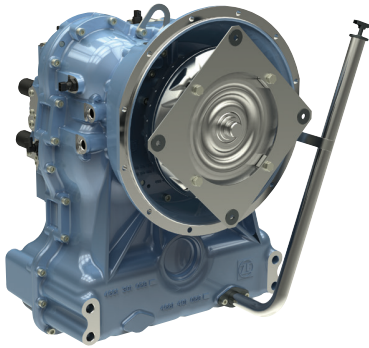

Full-Automatic Transmission

Full-automatic transmission gives easy, convenient handling and soft, smooth shifting. The operator can select two kinds of automatic modes.

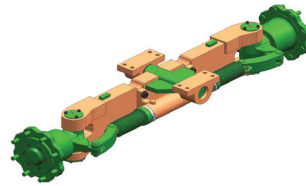

Fully Hydrostatic Power Steering

The hydraulic steering system always guarantees smooth and flexible steering, preventing over-run and kick-back.



Highly Durable Split Type Drive Axle

The durable drive axle provides fast travel speed and quiet travel under any heavy load conditions to boost work efficiency.



Wet Disc Brake System

The wet disc brake system is virtually maintenance free and is enclosed to protect from dust and water.

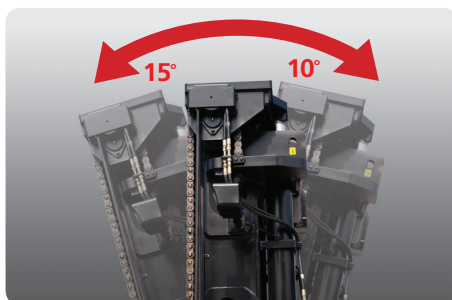

Increased Mast Tilting Angle

Utilizing the mast tilting angle of 15 degrees forward and 10 degrees backward, the operator can perform loading and unloading jobs safely and rapidly. (Optional angles are available; 15/6degree & 6/6degree)



Max. Gradeability (loaded/Unloaded)

Model	%
80D-9	35.2 / 26.5

Max. Travel Speed (Unloaded)

Model	mph
80D-9	22

Faster Travel Speed & Better Gradability

The powerful engine provides dynamic acceleration, excellent gradability and optimal travel speed on any tough terrains or slopes.

Best Convenience & Optimized Ergonomics



Spacious Operator Cabin

Some of the photos may include optional equipment.

The newly designed cab optimizes space for a wide field of view and operator comfort.



Centralized Instrument Switch Panel



Grammer Seat (STD)

An attractive and adjustable seat, based on a human engineering design, provides great comfort and is highly durable. And the angle of the armrest can be adjusted to reduce the fatigue of the driver.

- Applied the weight of the driver(45~170kg)
- ELR type seat belt standard
- Heater and Head Rest (Option)



MP3 CD Player

The ergonomically designed cab provides full support and comfort to the operator.

80D-9



Quick Response of Operating Control Levers
Minimal operator effort is required for precise, safe and productive control.

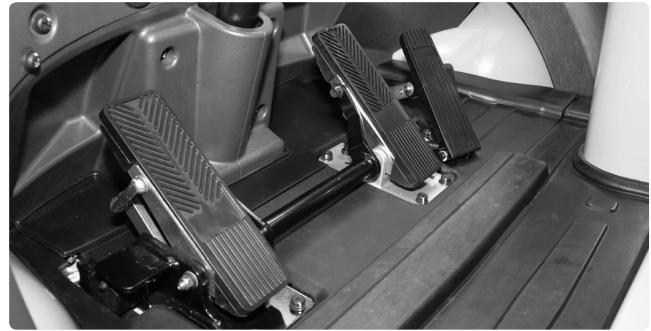

Ergonomically Positioned Pedals
Based on human engineering, the accelerator, brake and inching pedals are optimally positioned for the operator's convenience.



Adjustable Steering Wheel

Steering wheel with horn button can be adjusted by a lever on the right-hand side for the most comfortable operator position.



High-Output Air Conditioner & Heater

Our air conditioner and heater with high output and multi-directional air flow provides a dependable and comfortable work environment.

Advanced **Safety**

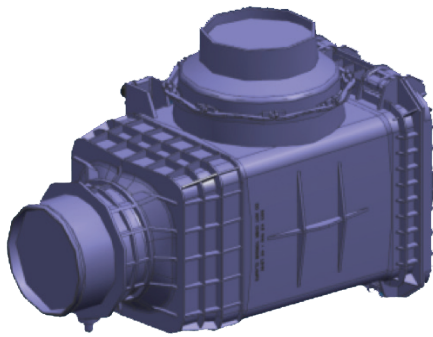

Direct Flow Air Cleaner

Cummins air cleaner introduced to enhance the performance of Tier-4 engines. More compact and efficient than previous cylindrical style air cleaners, it offers simple filter element change with capability to extend intervals



Electrically Monitored Air Filter

Air cleaner sensor alerts the operator of a clogged air filter to allow replacement before damage occurs.



Exterior

A strong overhead guard, which meets ISO 6055 regulation, protects the operator in hazardous jobs.

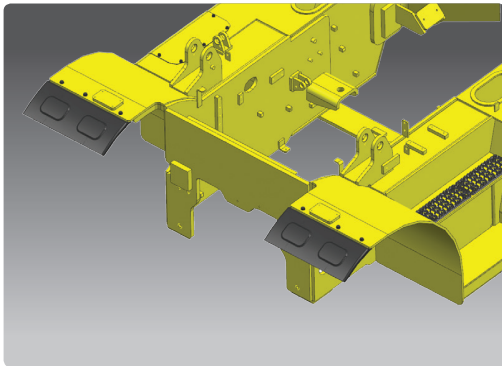

Front Mudguard STD.

Front mud guards protect the equipment from debris that could enter by the front tires.



Cab Tilt System

The cab tilt system makes servicing of all power train components quick and easy. An electrically assisted hydraulic actuated cylinder tilts operator cab to right side about 42.5 degrees for open access to truck components.

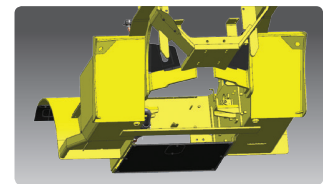

Under Cover (Option)

The Under cover protects the engine and components from ground dusts and debris which helps lengthen components life.

The safely designed driver's space makes your operating more comfortable.

80D-9

**OPSS
(Operator Presence Sensing System)**

When the operator is not in the seat all mast and drive movements are inoperable.

Lift Lock

Tilt Lock

Drive Lock



Some of the photos may include optional equipment.

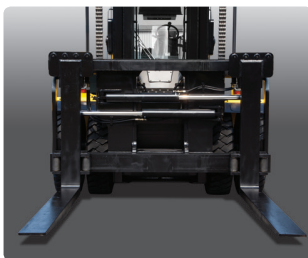

Highly Durable Carriage

The carriage is very strong and is constructed by high tensile structural steel which has a excellent durability.



Large Footboard & Handle

Wide "open" step offers convenience and safety when entering and exiting the truck.



Excellent Lights

- Various position of work lamp provides the operator great visibility and a safe operating environment.
- On Cab:
 - 2 Front head lamps
 - 1 Rear work lamp
 - 1 beacon lamp (optional)
- LED Rear Combination lamps



Bright, Protected Head Lights

Fast and Easy Maintenance



Tilting Cab & Large Engine Hood

Highly accessible engine compartment assures fast and efficient maintenance.

Some of the photos may include optional equipment.

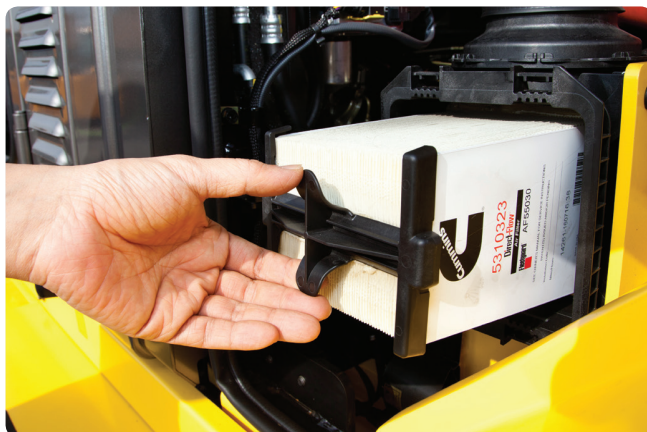

Easy Change Air Cleaner

This air filter is easily accessible for cleaning or replacement.

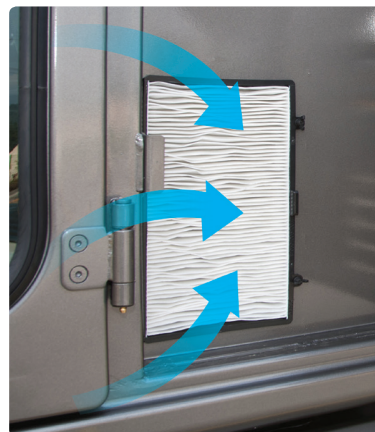

Cabin Air Fresh Filter

The internal pressure is maintained to be slightly higher than that of outside to exclude dust and to reduce noise levels.

An ideal arrangement of components ensures easy access and convenience for maintenance.

80D-9



Grease Inlet



Maintenance Free Battery



Rear View Camera (Option)

The rear view camera provides great rear visibility and the monitor supports 4 camera channels for operator convenience.



Pre-Cleaner



Fuel Cap



Some of the photos may include optional equipment.



Master Switch

A master switch disconnects the battery power to protect the electrical system from excess electrical drainage.



Maintenance Management Display

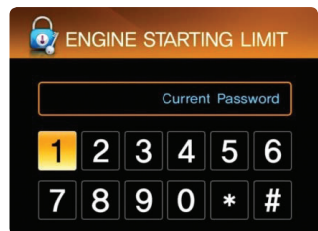

Engine Start Limit

Mast Specification (Hook/Shaft Type)

Standard : Hook-On Type Fork & Carriage

Model	Mast Type	Maximum Fork height		Overall Height						Free Lift				Tilt Angle TRUCK		Load capacity w/o side shift At 24 in (600mm)LC		Load capacity w/integral side shift At 24 in (600mm)LC		TRUCK WEIGHT UNLOADED		
				Low ered		Extended		Without Load Backrest		With Std Load Backrest		Fwd	Bwd	deg	deg	lb	kg	lb	kg	lb	kg	
						in	mm															in
80D-9	2-STAGE LIMITED FREE LIFT	V270	107.9	2740	99.4	2525	159.4	4048	159.4	4050	5.9	150	5.9	150	15	10	17500	8000	17500	8000	25487	11559
		V300	119.7	3040	105.3	2675	171.2	4348	171.3	4350	5.9	150	5.9	150	15	10	17500	8000	17500	8000	25595	11608
		V330	131.5	3340	111.2	2825	183.0	4648	183.1	4650	5.9	150	5.9	150	15	10	17500	8000	17500	8000	25703	11657
		V350	139.4	3540	115.2	2925	190.9	4848	190.9	4850	5.9	150	5.9	150	15	10	17500	8000	17500	8000	25776	11690
		V370	147.2	3740	119.1	3025	198.7	5048	198.8	5050	5.9	150	5.9	150	15	10	17500	8000	17500	8000	25847	11722
		V400	159.1	4040	125.0	3175	210.6	5348	210.6	5350	5.9	150	5.9	150	15	10	17500	8000	17500	8000	25955	11771
		V450	178.7	4540	136.8	3475	230.2	5848	230.3	5850	5.9	150	5.9	150	15	10	17500	8000	17500	8000	26429	11986
		V500	198.4	5040	146.7	3725	249.9	6348	250.0	6350	5.9	150	5.9	150	15	10	17500	8000	17500	8000	26609	12067
		V550	218.1	5540	156.5	3975	269.6	6848	269.7	6850	5.9	150	5.9	150	15	10	17500	8000	16979	7700	26788	12149
		V600	237.8	6040	166.3	4225	289.3	7348	289.4	7350	5.9	150	5.9	150	15	10	17420	7900	16538	7500	26969	12231
		V700	277.2	7040	186.0	4725	328.7	8348	328.7	8350	5.9	150	5.9	150	15	6	16538	7500	15656	7100	27421	12436
	V750	296.9	7540	195.9	4975	348.3	8848	348.4	8850	5.9	150	5.9	150	15	6	16097	7300	15215	6900	27606	12520	
	3-STAGE FULL FREE LIFT	TF/TS 450	179.9	4570	108.3	2750	232.4	5902	231.5	5880	55.8	1418	56.7	1440	15	10	17500	8000	17500	8000	27055	12270
		TF/TS 500	199.6	5070	116.1	2950	252.0	6402	251.2	6380	63.7	1618	64.6	1640	15	10	17500	8000	17200	7800	27282	12373
TF/TS 550		223.2	5670	124.0	3150	271.7	6902	270.9	6880	71.6	1818	72.4	1840	15	10	17500	8000	16759	7600	27507	12475	
TF/TS 600		239.0	6070	131.9	3350	291.4	7402	290.6	7380	79.4	2018	80.3	2040	15	10	17200	7800	16318	7400	27734	12578	

Option : Shaft Type Fork & Carriage

Model	Mast Type	Maximum Fork height		Overall Height				Free Lift		Tilt Angle		Load capacity w/o side shift At 24 in (600mm)LC		Load capacity w/integral side shift At 24 in (600mm)LC		TRUCK WEIGHT UNLOADED			
				Low ered		Extended				Fwd	Bwd	deg	deg	lb	kg	lb	kg	lb	kg
				in	mm	in	mm												
80D-9	2-STAGE LIMITED FREE LIFT	V270	107.9	2740	99.4	2525	160.4	4075	5.9	150	15	10	17500	8000	17500	8000	25461	11547	
		V300	119.7	3040	105.3	2675	172.2	4375	5.9	150	15	10	17500	8000	17500	8000	25569	11596	
		V330	131.5	3340	111.2	2825	184.1	4675	5.9	150	15	10	17500	8000	17500	8000	25677	11645	
		V350	139.4	3540	115.2	2925	191.9	4875	5.9	150	15	10	17500	8000	17500	8000	25750	11678	
		V370	147.2	3740	119.1	3025	199.8	5075	5.9	150	15	10	17500	8000	17500	8000	25820	11710	
		V400	159.1	4040	125.0	3175	211.6	5375	5.9	150	15	10	17500	8000	17500	8000	25928	11759	
		V450	178.7	4540	136.8	3475	231.3	5875	5.9	150	15	10	17500	8000	17500	8000	26402	11974	
		V500	198.4	5040	146.7	3725	251.0	6375	5.9	150	15	10	17500	8000	17420	7900	26582	12055	
		V550	218.1	5540	156.5	3975	270.7	6875	5.9	150	15	10	17500	8000	16979	7700	26762	12137	
		V600	237.8	6040	166.3	4225	290.4	7375	5.9	150	15	10	17420	7900	16318	7400	26943	12219	
		V700	277.2	7040	186.0	4725	329.7	8375	5.9	150	15	6	16538	7500	15436	7000	27395	12424	
	V750	296.9	7540	195.9	4975	349.4	8875	5.9	150	15	6	16097	7300	14994	6800	27580	12508		
	3-STAGE FULL FREE LIFT	TF/TS 450	179.9	4570	108.3	2750	232.5	5905	55.7	1415	15	10	17500	8000	17500	8000	26998	12244	
		TF/TS 500	199.6	5070	116.1	2950	252.2	6405	63.6	1615	15	10	17500	8000	17200	7800	27225	12347	
TF/TS 550		223.2	5670	124.0	3150	271.9	6905	71.5	1815	15	10	17500	8000	16759	7600	27450	12449		
TF/TS 600		239.0	6070	131.9	3350	291.5	7405	79.3	2015	15	10	17200	7800	16318	7400	27677	12552		

Load Capacity

HOOK TYPE

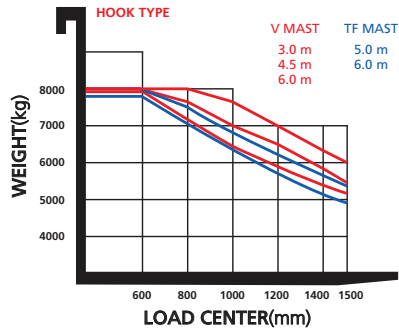

SHAFT TYPE

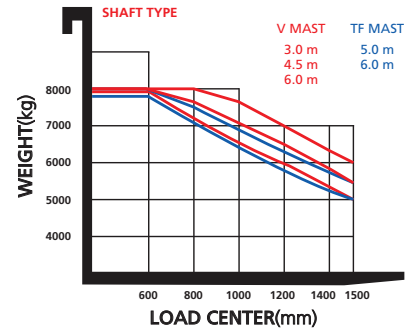

Various Attachments

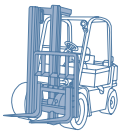

Side Shift

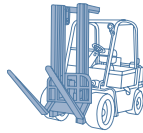

Hinged Fork



Hinged Bucket



Rotating Fork

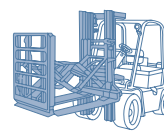

Push Pull

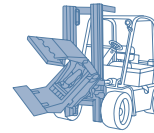

Rotating Roll Clamp

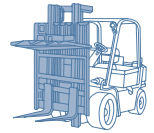

Load Stabilizer

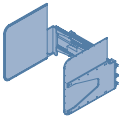

Carton Clamp

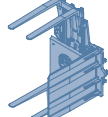

Pallet Invert

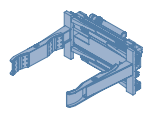

Drum Clamp

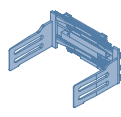

Bale Clamp

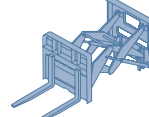

Load Extender



Fork Positioner

Optional Items

· FORK (L x W x T) (in)

HOOK TYPE

80D-9 · 53 x 7 x 3 · 59 x 7 x 3 · 71 x 7 x 3
· 79 x 7 x 3 · 94 x 7 x 3

SHAFT TYPE

80D-9 · 53 x 7 x 3 · 59 x 7 x 3 · 71 x 7 x 3
· 79 x 7 x 3 · 94 x 7 x 3

· OVER SHOE 71 / 79 / 87 / 91

· TIRE SOLID

· SEAT ARM REST, HEAT, BACKREST EXT, BUCKLE SW

· CABIN & HEATER CABIN, AIRCON+HEATER

· MASTER SWITCH

· BEACON LAMP

· MCV 3-SPOOL / 4-SPOOL / 5-SPOOL

· INTEGRAL FORK POSITIONER CARRIAGE (SHAFT TYPE)

· INTEGRAL SIDE SHIFT CARRIAGE (SHAFT TYPE)

· INTEGRAL SIDE SHIFT WITH FORK POSITIONER CARRIAGE (SHAFT TYPE)

· REAR VIEW CAMERA

· LOAD INDICATOR

· 3STAGE FULL FREE LIFT DUAL FREE CYL TYPE

Notes

Notes

Dimension

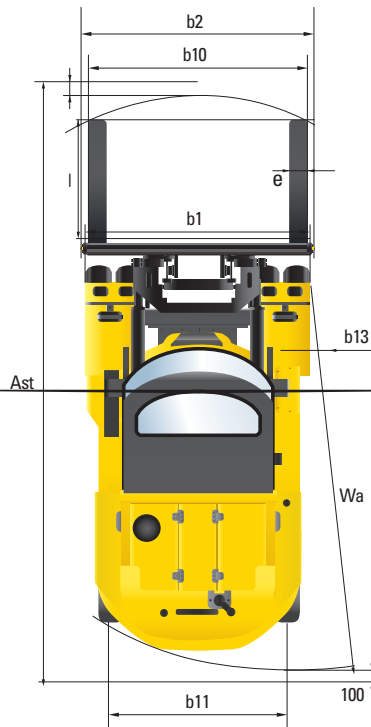
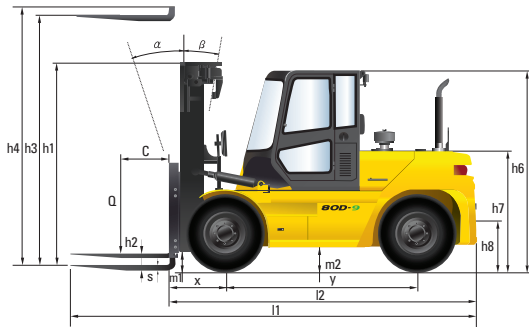

Specification

Identification		80D-9
1.1	Manufacturer	Hyundai
1.2	Manufacturer's model designation	80D-9
1.3	Drive: electric (battery or mains), diesel, petrol, fuel gas, manual	DIESEL
1.4	Type of operation: hand, pedestrian, standing, seated, order-picker	seated
1.5	Load capacity / rated load	lb 17,400
1.7	Load center distance	c in 24
1.8	Load distance, center of drive axle to fork	x in 27
1.9	Wheelbase	y in 98
Weights		
2.1	Service weight	lb 25,591
2.2	Axle loading, loaded front/rear	lb 38,034 / 5,384
2.3	Axle loading, unloaded front/rear	lb 11,310 / 14,484
Wheels, Chassis		
3.1	Tires: solid rubber, superelastic, pneumatic, polyurethane	pneumatic
3.2	Tires size, front	9.00-20-14PR
3.3	Tires size, rear	9.00-20-14PR
3.5	Number of wheels front / rear (x=driven)	4 x / 2
3.6	Track width, front	b10 in 64
3.7	Track width, rear	b11 in 67
Basic Dimensions		
4.1	Mast / fork carriage tilt forward / backward	α/β degree 15° / 10°
4.2	Lowered mast height	h1 in 105
4.3	Free lift	h2 in 6
4.4	Lift height	h3 in 120
4.5	Extended mast height	h4 in 172
4.7	Overhead guard height	h6 in 104
4.8	Seat height / standing height rel. to SIP	h7 in 65
4.12	Coupling height	h10 in 20
4.19	Overall length	l1 in 209
4.20	Length to face of forks	l2 in 156
4.21	Overall width	b1 in 86
4.22	Fork dimensions	s/e/l in 3 x 7 x 47
4.23	Fork carriage ISO 2328, class / type A,B	Class IV
4.24	Fork-carriage width	b2 in 89
4.31	Ground clearance under mast, loaded	m1 in 10
4.32	Ground clearance center of wheelbase	m2 in 12
4.33	Aisle width for pallets 1,000 x 1,200 crossways (L x W)	Ast in 220
4.34	Aisle width for pallets 800 x 1,200 lengthways (W x L)	Ast in 228
4.35	Turning radius	Wa in 146
4.36	Smallest pivot point distance	b13 in 1,354
Performance Data		
5.1	Travel speed, unloaded	mph 22
5.2	Lift speed, loaded / unloaded	ft/min 81 / 94
5.3	Lowering speed, loaded / unloaded	ft/min 98 / 98
5.5	Max drawbar pull, loaded	N 70,010
5.7	Gradeability, loaded	% 35.2
5.10	Service brake	FOOT(Hydraulic)
Engine		
6.1	Engine manufacturer / type	CUMMINS / QSF3.8
6.2	Engine power acc. To ISO 1585	hp/rpm 100.6/2200
6.3	Maximum torque	lbft/rpm 306/1600
6.4	No. of cylinder / displacement	/ cc 4/3800
6.5	Fuel consumption acc. To VDI cycle	ℓ/h 8.5
Other Details		
8.1	Type of drive control	Full Auto
8.2	Operating pressure (system / attach)	kg/in ² 463 / 23
8.3	Oil volume (hydraulic)	ℓ 115
8.4	Sound level (at driver's ear according to DIN 12 053)	dB(A) 78.6
8.5	Trailer coupling, type DIN	Pin

 **HYUNDAI | FORKLIFT**
CONSTRUCTION EQUIPMENT AMERICAS, INC.

6100 Atlantic Blvd Norcross, GA 30071
TEL (678) 823 7777 FAX (678) 823 7778

PLEASE CONTACT

www.hceamericas.com

2015. 03 Rev. 0