

40/45/50B-9

Electric Counterbalance Trucks

MOVING YOU FURTHER

HYUNDAI HEAVY INDUSTRIES



*Photo may include optional equipment.

 **HYUNDAI**

Your satisfaction is **our priority!**

Hyundai introduces a new line of **9-series** battery forklift trucks.

The newly designed 4 wheel counterbalance trucks provide every operator comfortable driving, increased productivity and easy maintenance.



Some of the photos may include optional equipment.

Compact forklift with proven AC technology

Maximum performance

Comfortable operating room

Load indicator

Battery side loading system

Curve control system

Fingertip controlled mini levers available (optional)

Safety system that prevents over loading (optional)



High Efficiency & Optimal Performance



More efficient operating control levers (Optional)

Electronic directional control and secondary horn are mounted to the hydraulic lift lever for quick and precise maneuvering.



Finger tip control levers (Optional)

The finger tip control lever allows more precise control and fatigue-free working. The ergonomically designed armrest can be adjusted up, down, forward and backward for various operator's body type.



Some of the photos may include optional equipment.



Advanced drive and lift performance with proven durability and low maintenance

The enclosed drive and pump motor with AC technology combine power, high maintenance intervals and excellent durability. The brushless AC motors offer improved efficiency and reduction maintenance cost.

Efficient, smooth running and powerful performance make your work more productive.

40/45/50B-9



Some of the photos may include optional equipment.



Auto fork leveling system (Optional)

In order to improve productivity the auto fork leveling system will automatically stop the tilt movement when the mast is in a straight position.

Curve control

Curve Control limits travel speed based on turning radius, reducing speed for a smooth, precise turning operation for the driver.



Driving Speed

Limit the speed



Dual drive system

The dual drive system enhances the operator's ability to maneuver in small aisle widths using minimum energy consumption. Plus, the drive units and AC motors intergrated in the front axle provide the operator with extremely improved gradient capacity.



Max.Gradeability (Loaded)

Model	%
40B-9	23
45B-9	21
50B-9	19

Max.Travel Speed (Unloaded)

Model	mph / km/h
40B-9	11.2 / 18.0
45B-9	11.2 / 18.0
50B-9	11.2 / 18.0

Anti roll back system, travel speed and gradeability

Anti Roll-back system offers protection against the machine rolling back on a ramp in combination with exceptional ramp start capabilities.

Advanced **Safety**



Some of the photos may include optional equipment.

Excellent visibility for safe operation

Optimized lift cylinder arrangement provides operator with wider visibility.



Panoramic mirror

The panoramic mirror expands the driver's view during operation.

Strong overhead guard

Exceeding EEC and ANSI regulations, the overhead guard offers great protection combined with excellent all around visibility.

The safely designed driver's space makes your operating more comfortable.

40/45/50B-9

Fork safety features

When the forks are being lowered, a down-control valve maintains the controlled speed. The down-safety valve prevents forks from dropping down in case of sudden damage of hydraulic line.

OPSS (Operator Presence Sensing System)

When the operator is not in the seat all mast and drive movements are inactive.

Lift Lock

Tilt Lock

Drive Lock



Some of the photos may include optional equipment.



Safety lamps & rear reflectors

LED combination lights and halogen headlights offer the driver visibility in all circumstances. Rear reflectors mounted on the counterweight enhance safety for the driver and the work area.

Optimized Ergonomics & Fast and Easy Maintenance



Some of the photos may include optional equipment.

Spacious operator cabin

The newly designed cabin was conceived for more space, a wider field of view and operator comfort.



Optimized pedal position and floor mat

The position of accelerator and throttle have been optimized through human engineering.



Large entrance step

Wide and non-slip step offers convenience and safety when entering and exiting truck.



Adjustable steering wheel

To achieve a comfortable drive position, the angle of the steering column can easily be adjusted through a lever on the right-hand side of the steering column.



Grammer seat

Based on a human engineering design, the easily adjustable suspension seat provides greater comfort reducing operator fatigue.

An ideal arrangement of components ensures easy access and convenience for maintenance.

40/45/50B-9



Some of the photos may include optional equipment.

Easy battery replacement

The battery compartment is equipped with a side battery removal assembly for easy removal and replacement.



Advanced LCD Monitor

The LCD color monitor with 3.5 inch graphic smart display allows the operator to easily and efficiently control the machine. The monitor provides information about speed & accelerator level, steer angle & travel direction, battery discharge indicator, hour meter & working mode. The load indicator displays the load weight in the monitor. The operator can select various performance modes to meet all working conditions. It is available multiple languages (maximum 12) for operator.

H (High) mode **N** (Normal) mode **E** (Economic) mode
Turtle mode

Brake oil reservoir with level sensor

The enhanced brake oil reservoir, located in the upper left dash, is equipped with an electronic level sensor and easily visible through the monitor.

Specification 9 Series

Mast Specification (40B-9)

Mast Type		Maximum Fork Height (in / mm)	Overall Height (Lowered) (in / mm)	Free Lift Height (mm / in)		Tilt Angle (deg) Fwd / Bwd	Load Capacity without side shift at 24 in LC (lb / kg)	Load Capacity with side shift at 24 in LC (lb / kg)	Truck Weight (Unloaded) (lb / kg)
				With Load Backrest	Without Load Backrest				
		40B-9	40B-9	40B-9	40B-9	40B-9	40B-9	40B-9	40B-9
2-Stage Limited free lift	V270	107.1 / 2,720	81.7 / 2,075	4.7 / 120	4.7 / 120	6 / 10	8,800 / 4,000	8,800 / 4,000	15,063 / 6,833
	* V300	118.9 / 3,020	87.6 / 2,225	4.7 / 120	4.7 / 120	6 / 10	8,800 / 4,000	8,800 / 4,000	15,120 / 6,858
	V330	130.7 / 3,320	93.5 / 2,375	4.7 / 120	4.7 / 120	6 / 10	8,800 / 4,000	8,800 / 4,000	15,176 / 6,884
	V350	138.6 / 3,520	99.4 / 2,525	4.7 / 120	4.7 / 120	6 / 10	8,800 / 4,000	8,800 / 4,000	15,230 / 6,908
	V370	146.5 / 3,720	103.3 / 2,625	4.7 / 120	4.7 / 120	6 / 10	8,800 / 4,000	8,690 / 3,950	15,266 / 6,925
	V400	158.3 / 4,020	111.6 / 2,835	4.7 / 120	4.7 / 120	6 / 10	8,800 / 4,000	8,580 / 3,900	15,344 / 6,960
	V450	178.0 / 4,520	121.5 / 3,085	4.7 / 120	4.7 / 120	6 / 6	8,800 / 4,000	8,030 / 3,650	15,436 / 7,002
3-Stage full free lift	V500	197.6 / 5,020	131.3 / 3,335	4.7 / 120	4.7 / 120	6 / 6	8,800 / 4,000	7,810 / 3,550	15,530 / 7,045
	TF370	146.9 / 3,730	79.7 / 2,025	44.8 / 1,139	32.0 / 812	6 / 6	8,800 / 4,000	8,250 / 3,750	15,728 / 7,134
	TF400	158.7 / 4,030	83.7 / 2,125	48.8 / 1,239	35.9 / 912	6 / 6	8,800 / 4,000	8,140 / 3,700	15,784 / 7,160
	TF430	170.5 / 4,330	87.6 / 2,225	52.7 / 1,339	39.8 / 1,012	6 / 6	8,800 / 4,000	8,030 / 3,650	15,841 / 7,185
	TF450	177.6 / 4,510	90.0 / 2,285	55.1 / 1,399	42.2 / 1,072	6 / 6	8,800 / 4,000	7,920 / 3,600	15,875 / 7,201
	TF470	185.8 / 4,720	93.5 / 2,375	58.6 / 1,489	45.7 / 1,162	6 / 6	8,690 / 3,950	7,810 / 3,550	15,926 / 7,224
	TF500	197.6 / 5,020	97.4 / 2,475	62.6 / 1,589	49.7 / 1,262	6 / 6	8,580 / 3,900	7,700 / 3,500	15,983 / 7,250
	TF550	217.3 / 5,520	104.5 / 2,655	69.6 / 1,769	56.8 / 1,442	6 / 6	8,250 / 3,750	7,480 / 3,400	16,097 / 7,301
	TF600	237.4 / 6,030	111.6 / 2,835	76.7 / 1,949	63.9 / 1,622	6 / 6	8,030 / 3,650	7,260 / 3,300	16,183 / 7,341

Mast Specification (45B-9)

Mast Type		Maximum Fork Height (in / mm)	Overall Height (Lowered) (in / mm)	Free Lift Height (in / mm)		Tilt Angle (deg) Fwd / Bwd	Load Capacity without side shift at 24 in LC (lb / kg)	Load Capacity with side shift at 24 in LC (lb / kg)	Truck Weight (Unloaded) (lb / kg)
				With Load Backrest	Without Load Backrest				
		45B-9	45B-9	45B-9	45B-9	45B-9	45B-9	45B-9	45B-9
2-Stage Limited free lift	V270	107.1 / 2,720	81.7 / 2,075	4.7 / 120	4.7 / 120	6 / 10	9,900 / 4,500	9,900 / 4,500	16,135 / 7,319
	* V300	118.9 / 3,020	87.6 / 2,225	4.7 / 120	4.7 / 120	6 / 10	9,900 / 4,500	9,900 / 4,500	16,192 / 7,345
	V330	130.7 / 3,320	93.5 / 2,375	4.7 / 120	4.7 / 120	6 / 10	9,900 / 4,500	9,900 / 4,500	16,249 / 7,370
	V350	138.6 / 3,520	99.4 / 2,525	4.7 / 120	4.7 / 120	6 / 10	9,900 / 4,500	9,790 / 4,450	16,303 / 7,395
	V370	146.5 / 3,720	103.3 / 2,625	4.7 / 120	4.7 / 120	6 / 10	9,900 / 4,500	9,680 / 4,400	16,339 / 7,411
	V400	158.3 / 4,020	111.6 / 2,835	4.7 / 120	4.7 / 120	6 / 10	9,900 / 4,500	9,460 / 4,300	16,417 / 7,447
	V450	178.0 / 4,520	121.5 / 3,085	4.7 / 120	4.7 / 120	6 / 6	9,900 / 4,500	9,130 / 4,150	16,510 / 7,489
3-Stage full free lift	V500	197.6 / 5,020	131.3 / 3,335	4.7 / 120	4.7 / 120	6 / 6	9,900 / 4,500	9,020 / 4,100	16,603 / 7,531
	TF370	146.9 / 3,730	79.7 / 2,025	44.8 / 1,139	32.0 / 812	6 / 6	9,900 / 4,500	9,240 / 4,200	16,619 / 7,538
	TF400	158.7 / 4,030	83.7 / 2,125	48.8 / 1,239	35.9 / 912	6 / 6	9,900 / 4,500	9,130 / 4,150	16,676 / 7,564
	TF430	170.5 / 4,330	87.6 / 2,225	52.7 / 1,339	39.8 / 1,012	6 / 6	9,900 / 4,500	9,020 / 4,100	16,733 / 7,590
	TF450	177.6 / 4,510	90.0 / 2,285	55.1 / 1,399	42.2 / 1,072	6 / 6	9,790 / 4,450	8,910 / 4,050	16,767 / 7,605
	TF470	185.8 / 4,720	93.5 / 2,375	58.6 / 1,489	45.7 / 1,162	6 / 6	9,680 / 4,400	8,800 / 4,000	16,819 / 7,629
	TF500	197.6 / 5,020	97.4 / 2,475	62.6 / 1,589	49.7 / 1,262	6 / 6	9,460 / 4,300	8,580 / 3,900	16,876 / 7,655
	TF550	217.3 / 5,520	104.5 / 2,655	69.6 / 1,769	56.8 / 1,442	6 / 6	9,240 / 4,200	8,360 / 3,800	16,991 / 7,707
	TF600	237.4 / 6,030	111.6 / 2,835	76.7 / 1,949	63.9 / 1,622	6 / 6	8,910 / 4,050	8,030 / 3,650	17,078 / 7,746

Mast Specification (50B-9)

Mast Type		Maximum Fork Height (in / mm)	Overall Height (Lowered) (in / mm)	Free Lift Height (in / mm)		Tilt Angle (deg) Fwd / Bwd	Load Capacity without side shift at 24 in LC (lb / kg)	Load Capacity with side shift at 24 in LC (lb / kg)	Truck Weight (Unloaded) (lb / kg)
				With Load Backrest	Without Load Backrest				
		50B-9	50B-9	50B-9	50B-9	50B-9	50B-9	50B-9	50B-9
2-Stage Limited free lift	V260	103.1 / 2,620	81.9 / 2,080	4.7 / 120	4.7 / 120	6 / 10	10,978 / 4,990	10,978 / 4,990	17,152 / 7,780
	* V290	115.0 / 2,920	87.8 / 2,230	4.7 / 120	4.7 / 120	6 / 10	10,978 / 4,990	10,978 / 4,990	17,209 / 7,806
	V320	126.8 / 3,220	93.7 / 2,380	4.7 / 120	4.7 / 120	6 / 10	10,978 / 4,990	10,978 / 4,990	17,265 / 7,831
	V340	134.6 / 3,420	99.6 / 2,530	4.7 / 120	4.7 / 120	6 / 10	10,978 / 4,990	10,978 / 4,990	17,320 / 7,856
	V360	142.5 / 3,620	103.5 / 2,630	4.7 / 120	4.7 / 120	6 / 10	10,978 / 4,990	10,978 / 4,990	17,356 / 7,873
	V390	154.3 / 3,920	111.8 / 2,840	4.7 / 120	4.7 / 120	6 / 10	10,978 / 4,990	10,978 / 4,990	17,434 / 7,908
	V440	174.0 / 4,420	121.7 / 3,090	4.7 / 120	4.7 / 120	6 / 6	10,978 / 4,990	10,780 / 4,900	17,527 / 7,950
3-Stage full free lift	V490	193.7 / 4,920	131.5 / 3,340	4.7 / 120	4.7 / 120	6 / 6	10,978 / 4,990	10,560 / 4,800	17,622 / 7,993
	TF360	144.2 / 3,662	79.9 / 2,030	42.3 / 1,074	31.8 / 807	6 / 6	10,978 / 4,990	10,780 / 4,900	17,510 / 7,942
	TF390	156.0 / 3,962	83.9 / 2,130	46.2 / 1,174	35.7 / 907	6 / 6	10,978 / 4,990	10,780 / 4,900	17,567 / 7,968
	TF420	167.8 / 4,262	87.8 / 2,230	50.2 / 1,274	39.6 / 1,007	6 / 6	10,978 / 4,990	10,560 / 4,800	17,623 / 7,994
	TF440	174.9 / 4,442	90.2 / 2,290	52.5 / 1,334	42.0 / 1,067	6 / 6	10,978 / 4,990	10,450 / 4,750	17,658 / 8,010
	TF460	183.1 / 4,652	93.7 / 2,380	56.1 / 1,424	45.6 / 1,157	6 / 6	10,780 / 4,900	10,340 / 4,700	17,709 / 8,033
	TF490	195.0 / 4,952	97.6 / 2,480	60.0 / 1,524	49.5 / 1,257	6 / 6	10,560 / 4,800	10,120 / 4,600	17,766 / 8,059
	TF540	214.6 / 5,452	104.7 / 2,660	67.1 / 1,704	56.6 / 1,437	6 / 6	10,340 / 4,700	9,680 / 4,400	17,880 / 8,110
	TF590	234.7 / 5,962	111.8 / 2,840	74.2 / 1,884	63.7 / 1,617	6 / 6	10,010 / 4,550	9,350 / 4,250	17,968 / 8,150

* Standard ※ TS-Mast : Wide Visible 3-Stage Full Free Lift Mast with 2 Free Lift Cylinders.

Load Capacity

40B-9

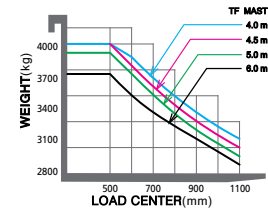
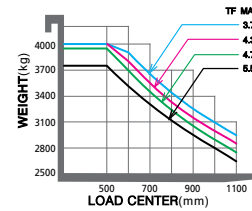
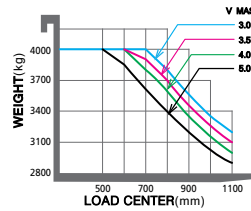
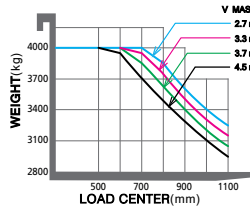

45B-9

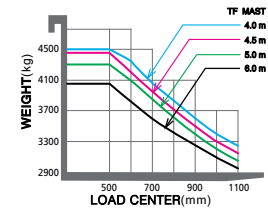
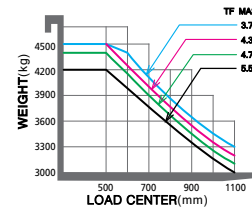
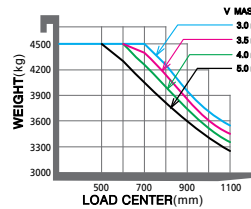
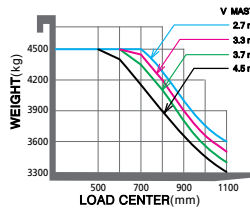

50B-9

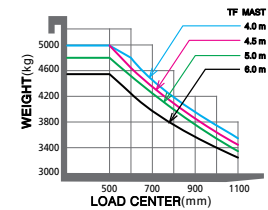
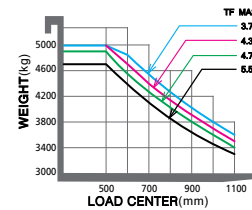
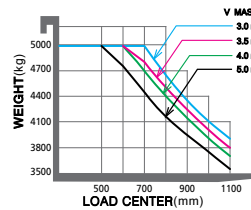
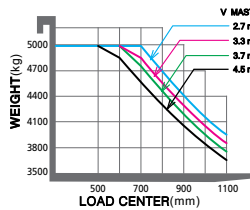

Various Attachments

Side Shift



Hinged Fork



Hinged Bucket



Rotating Fork



Push Pull

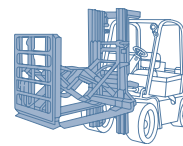

Rotating Roll Clamp

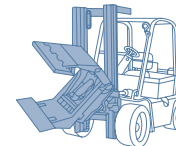

Load Stabilizer

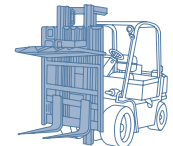

Carton Clamp

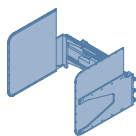

Pallet Invert

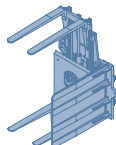

Drum Clamp

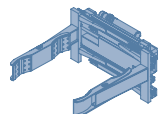

Bale Clamp

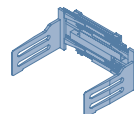

Load Extender

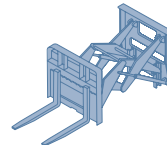

Fork Positioner

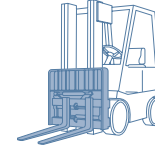

Optional Items

- Fork (in)

40B-9 : 42.1 (STD), 48.0, 53.9, 59.8, 65.7, 71.7, 77.6, 83.5, 94.5

45B-9 : 42.1 (STD), 48.0, 53.9, 59.8, 65.7, 71.7, 77.6, 83.5

50B-9 : 42.1 (STD), 48.0, 53.9, 65.7, 71.7, 77.6, 86.6

- Overshoe (in)

40/45/50B-9 : 70.9, 78.7, 86.6

- Sideshift

• Tire : Solid (STD) / Pneumatic / Non-marking / Double Tire

• Seat : KAB

• Finger Tip Control

- Cold Storage (for -30° cold working environments)

- M.C.V : 2-Spool (STD), 3-Spool, 4-Spool

- Auto Fork Leveling

- Beacon Lamp

- Work Lamp

- OPSS : Mast

- UL : ES, EE

- Cabin

- Direction Switch on Lever

Dimension

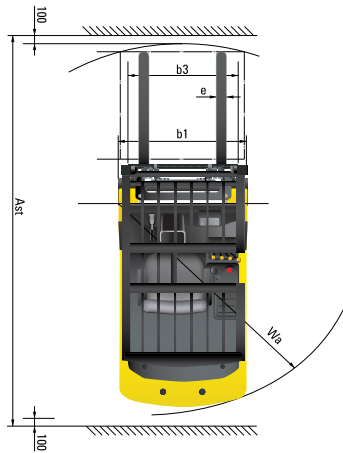
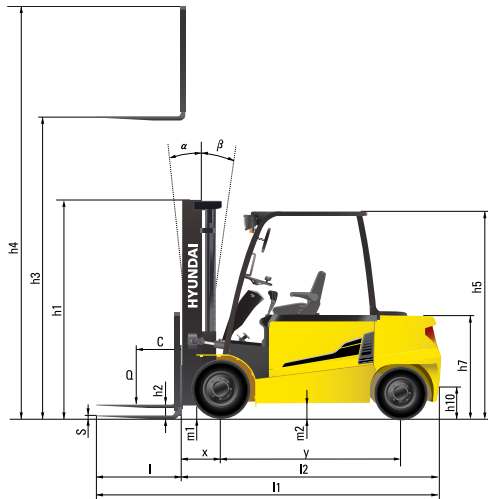

Specification

Identification

		HYUNDAI		
1. 1	Manufacturer	HYUNDAI		
1. 2	Manufacturer's type designation	40B-9	45B-9	50B-9
1. 3	Drive : electric(battery or mains) ,diesel, petrol, fuel gas, manual	electric	electric	electric
1. 4	Type of operation : hand, pedestrian, standing, seated, order - picker	seated	seated	seated
1. 5	Load capacity / rated load Q (lb / kg)	8,800 / 4,000	9,900 / 4,500	11,000 / 5,000
1. 6	Load center distance c (in / mm)	20 / 500	20 / 500	20 / 500
1. 7	Load distance, center of drive axle to fork x (in / mm)	21.1 / 535	21.1 / 535	21.3 / 540
1. 8	Wheelbase y (in / mm)	79.7 / 2,025	79.7 / 2,025	79.7 / 2,025

Weights

2. 1	Service weight (lb / kg)	15,113 / 6,855	16,193 / 7,345	17,207 / 7,805
2. 2	Axle loading, loaded front / rear (lb)	21,050 - 2,881	23,052 - 3,062	24,983 - 3,225
2. 3	Axle loading , unloaded front / rear (lb)	7,725 - 7,388	8,060 - 8,133	8,331 - 8,876

Wheels, Chassis

3. 1	Tires : solid rubber(V), superelastic(SE), pneumatic(P), polyurethane(PE)	SE, P	SE, P	SE, P
3. 2	Tires size, front (Φ x width)	250-15	250-15	28X12.5-15
3. 3	Tires size, rear (Φ x width)	23X9-10	23X9-10	23X9-10
3. 4	Wheels, number front rear(x = driven wheels)	2x2	2x2	2x2
3. 5	Track width, front (in / mm)	44.9 / 1,141	44.9 / 1,141	43.9 / 1,114
3. 6	Track width, rear (in / mm)	43.2 / 1,098	43.2 / 1,098	43.2 / 1,098

Basic Dimensions

4. 1	Mast / fork carriage tilt forward / backward (deg)	6/10	6/10	6/10
4. 2	Lowered mast height h1 (in / mm)	87.6 / 2,225	87.6 / 2,225	87.8 / 2,230
4. 3	Free lift height h2 (in / mm)	4.7 / 120	4.7 / 120	4.7 / 120
4. 4	Lift height h3 (in / mm)	118.9 / 3,020	118.9 / 3,020	115.0 / 2,920
4. 5	Extended mast height h4 (in / mm)	166.3 / 4,224	166.3 / 4,224	163.2 / 4,146
4. 6	Overhead guard (cab) height h5 (in / mm)	91.3 / 2,320	91.3 / 2,320	91.3 / 2,320
4. 7	Seat height / Standing height h7 (in / mm)	46.3 / 1,176	46.3 / 1,176	46.3 / 1,176
4. 8	Coupling height h10 (in / mm)	18.1 / 460	18.1 / 460	18.1 / 460
4. 9	Overall length l1 (in / mm)	160.0 / 4,065	160.0 / 4,065	161.8 / 4,110
4. 10	Length to face of forks l2 (in / mm)	117.9 / 2,995	117.9 / 2,995	119.7 / 3,040
4. 11	Overall width b1 (in / mm)	53.9 / 1,370	53.9 / 1,370	56.1 / 1,424
4. 12	Fork dimensions ℓ / e / s (in)	2.0 x 4.8 x 42.1	2.0 x 5.9 x 42.1	2.0 x 5.9 x 42.1
4. 13	Fork carriage ISO 2328, class / type A, B	III / A	III / A	III / A
4. 14	Fork - carriage width b3 (in / mm)	54.2 / 1,376	54.2 / 1,376	54.2 / 1,376
4. 15	Ground clearance, loaded, under mast m1 (in / mm)	6.3 / 160	6.3 / 160	6.5 / 165
4. 16	Ground clearance, centre of wheelbase m2 (in / mm)	5.9 / 150	5.9 / 150	6.1 / 155
4. 17	Aisle width for pallets 1,000 x 1,200 crossways Ast (in / mm)	173.4 / 4,405	173.4 / 4,405	175.0 / 4,445
4. 18	Aisle width for pallets 800 x 1,200 lengthways Ast (in / mm)	181.3 / 4,605	181.3 / 4,605	182.9 / 4,645
4. 19	Turning radius Wa (in / mm)	105.1 / 2,670	105.1 / 2,670	106.5 / 2,705

Performance Data

5. 1	Travel speed, loaded/unloaded (80V) (mph)	10.6 - 10.6	10.6 - 10.6	10.6 - 10.6
5. 2	Lift speed, loaded/ unloaded (80V) (ft/s)	1.2 / 1.7	1.1 / 1.6	1.1 / 1.5
5. 3	Lowering speed, loaded/unloaded (ft/s)	1.6 / 1.5	1.6 / 1.5	1.6 / 1.4
5. 4	Max. drawbar pull, loaded/ unloaded S2 5min (N)	28,185 / 29,075	28,662 / 29,003	28,558 / 28,469
5. 5	Max. gradient performance, loaded/ unloaded S2 5min (%)	23 / 25	21 / 23	19 / 22
5. 6	Service brake	Hydraulic	Hydraulic	Hydraulic

E - Motor

6. 1	Drive motor rating S2 60 min (80V) (HP / kW)	13.4 / 10.0 x2	13.4 / 10.0 x2	13.4 / 10.0 x2
6. 2	Pump motor rating at S3 - 15 % (80V) (HP / kW)	37.5 / 28	37.5 / 28	37.5 / 28
6. 3	Battery voltage (V)	80	80	80
6. 4	Battery weight (lb / kg)	4,619 / 2,095	4,619 / 2,095	4,619 / 2,095
6. 5	Battery compartment dimensions L / W / H (in)	40.7 / 39.5 / 30.9	40.7 / 39.5 / 30.9	40.7 / 39.5 / 30.9

Other Details

7. 1	Type of drive control	AC	AC	AC
------	-----------------------	----	----	----



Headquarter Office

6100 Atlantic Blvd, Norcross, GA 30071
TEL (678) 823 7777 / FAX (678) 823 7778

Chicago Office

955 Estes Ave, Elk Grove, IL 60007

PLEASE CONTACT

company_name

brochure dealer infocity, state zip
brochure dealer info 2

