

35/40/45D-9 50DA-9

Diesel Counterbalance Trucks

HYUNDAI HEAVY INDUSTRIES



 **HYUNDAI**
FORKLIFT

Your satisfaction is **our priority!**

Hyundai introduces a new line of 9-series diesel forklift trucks. The newly designed 4-wheel counterbalance trucks provide operator increased productivity and easy maintenance.



Proven quality and advanced technology

- Maximum performance
- Spacious operator cab
- 5.6 inch LCD color monitor
- Truck inclination warning system
- Operator presence sensing system (OPSS) for safe operation
- Easy serviceability
- Maximum speed limit function
- Password starting system
- Auto fork leveling system (optional)
- LED rear work lamp (optional)
- Weight indicator

Photos may include optional equipment.



High efficiency, optimal performance



Photos may include optional equipment.

CUMMINS QSF3.8 Engine

101 hp / 2,200 rpm

306 lbf-ft / 1,600 rpm

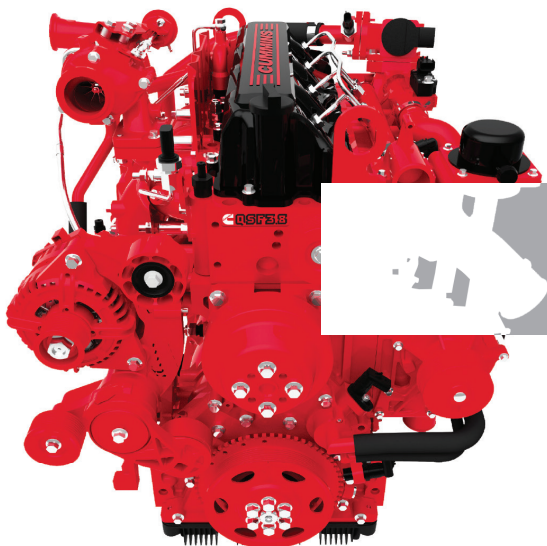

Powerful engine

The four-cylinder, turbo-charged engine is built for power, reliability and economy. This engine meets EPA Tier 4 and EU Stage IV emissions regulations.

High-pressure common rail (HPCR) fuel system

The upgraded HPCR fuel system provides an excellent start of injection.

Emissions control

- Combustion efficiency enhancement
- Low noise, Low vibration

Selective catalytic reduction (SCR)

- Reduces NOx emissions to near-zero levels
- No diesel particulate filter (DPF)

A powerful engine and high-tech systems combine to provide enhanced performance and productivity.

35/40/45D-9 50DA-9

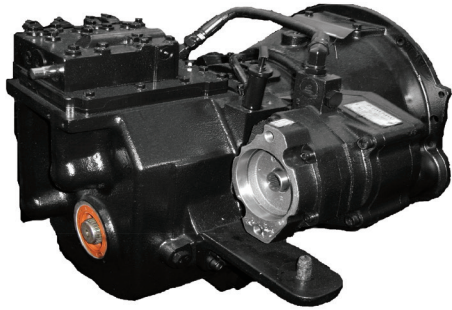

Highly durable transmission

The strengthened drive axle, separable from the transmission, ensures low vibration and easy maintenance. The maintenance-free wet disc brakes are easy to operate and deliver smooth response.



Boosting type brake valve

The boosting type brake valve provides strong braking performance.

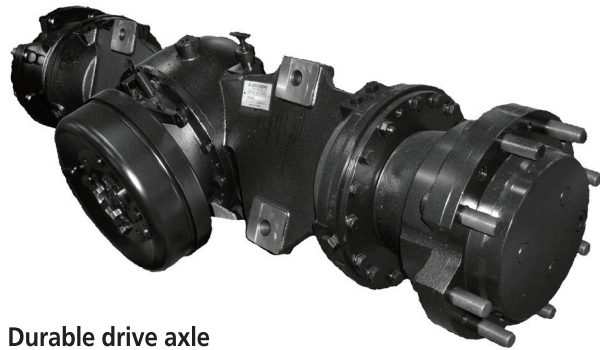

Durable drive axle

The strengthened drive axle separable from transmission ensures low vibration and easy maintenance. The wet disc type brake is applied for easy operation, smooth response and maintenance free.



Integrated wheel rim

The integrated wheel rim provides significantly increased service life.



Fully hydrostatic power steering

The hydraulic steering system ensures smooth and flexible steering, preventing overrun and kick-back.



Maximum travel speed

Model	mph
35D-9	16.5
40D-9	16.0
45D-9	15.9
50DA-9	15.9

Maximum gradeability

Model	%
35D-9	40.9 (22.2)
40D-9	36.4 (20.0)
45D-9	33.2 (18.4)
50DA-9	30.6 (17.0)

Unmatched convenience, **optimized ergonomics**



Spacious operator cabin

The newly designed cab provides more space, a wider field of view and greater operator comfort.



Optimized pedal position

The pedals are mounted to the console to reduce operator fatigue and noise, and to prevent dust from entering the engine compartment.



Adjustable steering wheel

The steering wheel can be adjusted by a right hand lever to set the most comfortable position for the operator.



Grammer seat (standard)

An adjustable ergonomic seat provides unmatched comfort. The adjustable armrest further reduces operator fatigue.

- Accommodates operator weights from 99 to 375 lb
- ELR type seat belt standard
- Heater and head rest (optional)

The ergonomically designed cab and new LCD color monitor provide complete operator comfort and support.

35/40/45D-9 50DA-9

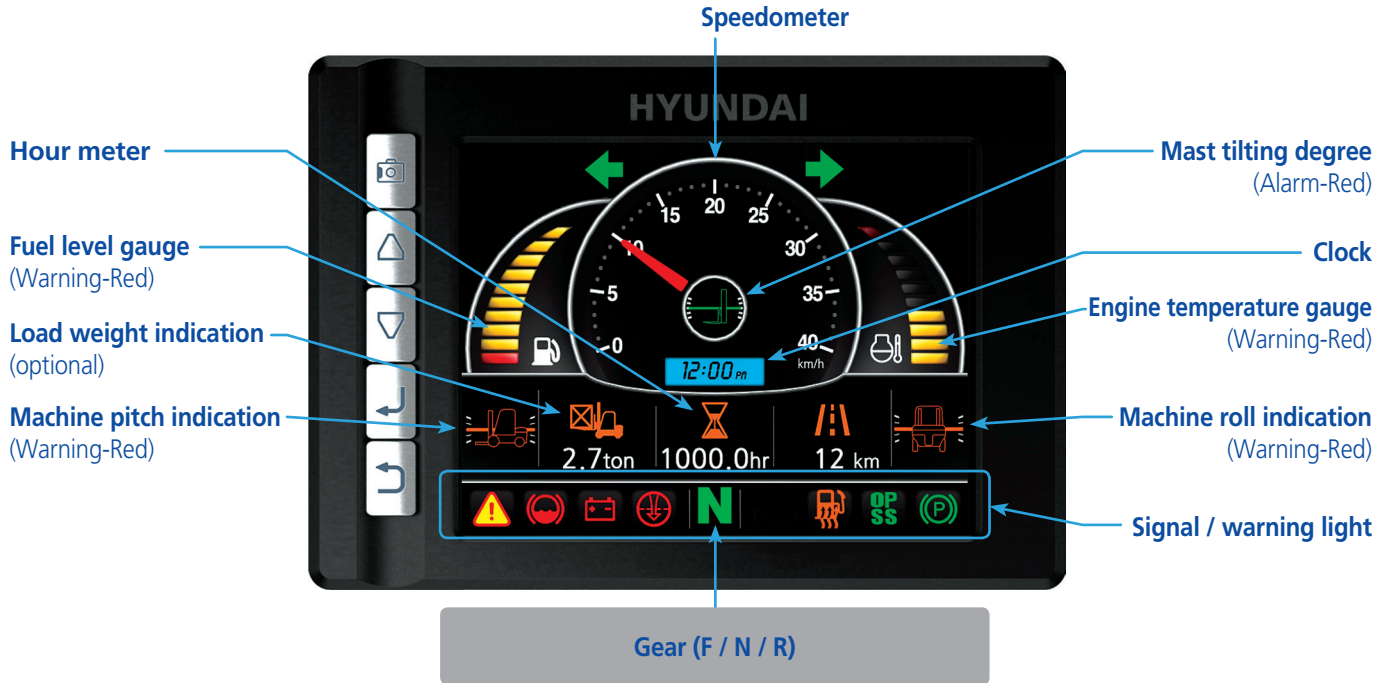

Advanced LCD monitor

The 5.6-inch wide LCD color monitor allows the operator to control the machine with ease and check speed, travel direction and battery discharge.



Automatic gear box

Automatic transmission is speed controlled:

- During acceleration, when the speed reaches 4 mph (7 km/h), second gear is selected.
- When decelerating, shifting down to first gear is done at 3 mph (5 km/h).

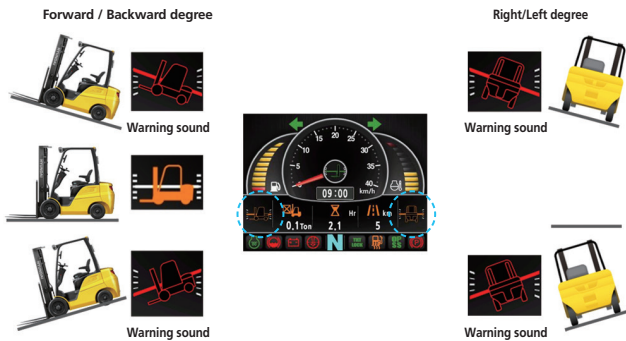

Truck inclination warning system

To improve the productivity and safety, the truck inclination warning system will monitor and indicate forward/backward, right/left degree of the forklift. The alarm alerts the operator when the forklift degree is over the ISO standard.

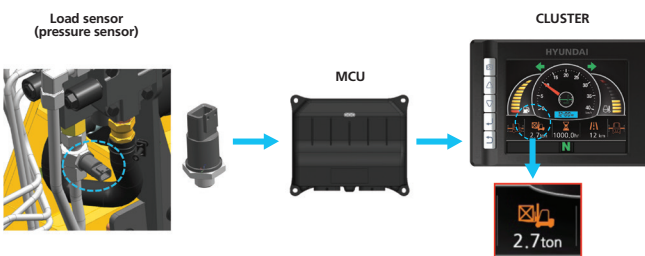

Weight indicator (optional)

The optional load indicator displays the load weight on the monitor. The load sensor reduces the time to check loaded weight and the alarm alerts the driver when overloaded.

Advanced **safety**



*Photos may include optional equipment.

Enhanced visibility, safer operation

Optimized lift cylinder arrangement provides operator with wider visibility. The panoramic mirror expands the driver's view when backing up.



Strong overhead guard

Offering optimal protection and visibility, the overhead guard exceeds CEE and ANSI regulations.



Low entrance height

The cab's low entrance height ensures safe, easy operator access.

The cab has been designed for enhanced operator comfort and safety.

35/40/45D-9 50DA-9

Fork safety features

When the forks are being lowered, a down-control valve maintains the controlled speed. The down-safety valve prevents forks from dropping down and causing sudden damage to the hydraulic line.

Operator presence sensing system (OPSS)

All mast and drive movements stop functioning when the operator is not in the seat.

Tilt Lock

Drive Lock

Lift Lock



*Photos may include optional equipment.



Safety lamps and rear reflectors

Halogen headlights and rear LED combination lights provide enhanced visibility throughout the day. Rear reflectors mounted on the counterweight further enhance safety for the driver and others working around the job site.

Fast, easy maintenance

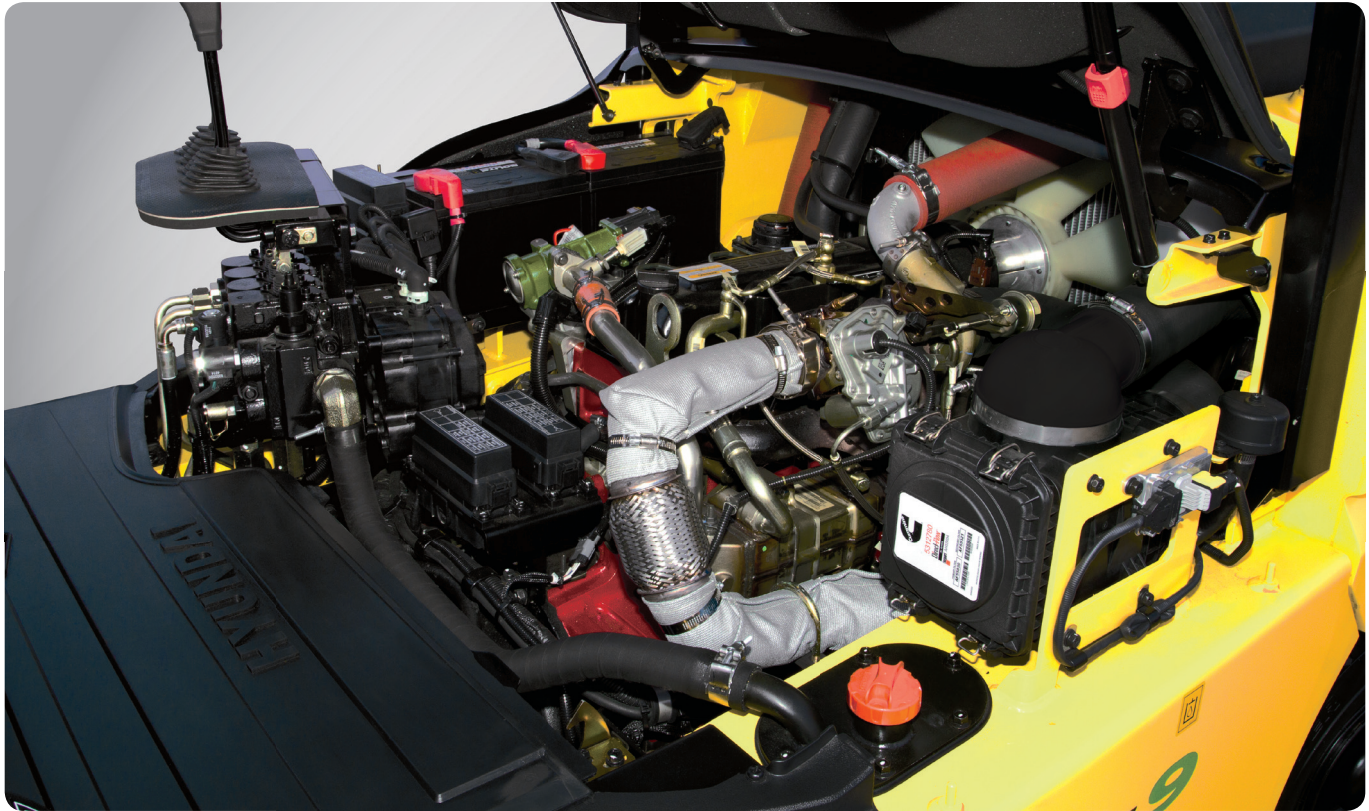

*Photos may include optional equipment.

Enlarged engine hood

The highly accessible engine compartment assures fast, efficient maintenance. The enlarged, 8-inch air cleaner extends engine life.

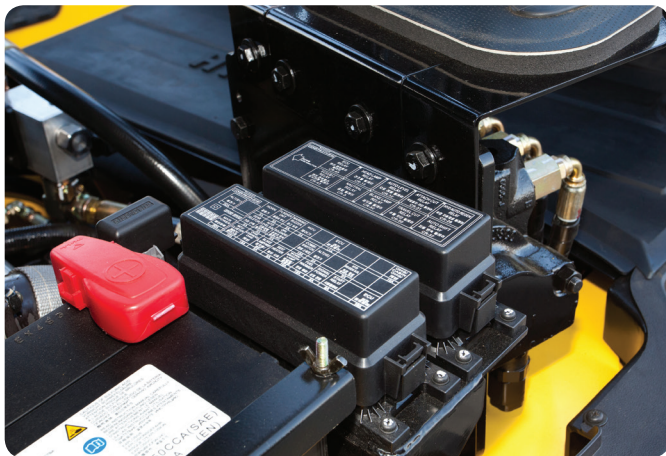

Water- and dust-proof cover

The newly developed water- and dust-proof fuse box and relay box ensure greater ease of maintenance.

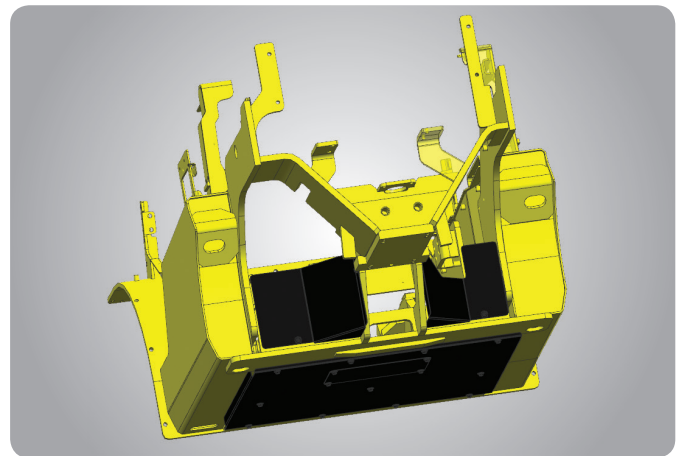

Rear tire cover

The cover prevents clogging and protects the radiator from damage caused by foreign materials.

Components are arranged for easy service and maintenance access.

35/40/45D-9 50DA-9



Optional rear-view camera



Emergency switch

*Photos may include optional equipment.

Maintenance Management			
Item	Interval	Elapse Count	Alarm
Axle Planetary Ge...	100	2 0	✓
Transmission Oil	100	2 0	✓
Transmission Oil F...	100	2 0	✓
Hydraulic Tank Ai...	250	2 0	✓
Air Cleaner Comp...	450	2 0	✓
Engine Oil Filter	500	2 0	✓

Maintenance management display

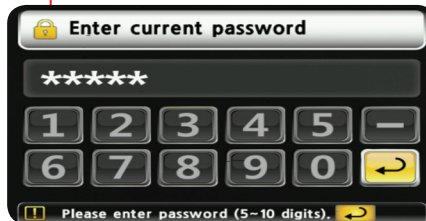

Password-protected starting system (anti-theft system)



Fuel cover with key

New 9 Series

Mast Specification (35D-9)

Mast Type		Maximum Fork Height	Overall Height (Lowered)		Free Lift Height		Tilt Angle		Load Capacity Without Side Shift		Load Capacity With Side Shift		Truck Weight Unloaded	
			Single Tire	Double Tire	With Load Backrest	Without Load Backrest	Fwd	Rev	Single Tire	Double Tire	Single Tire	Double Tire	Single Tire	Double Tire
			in	in	in	in	in	deg	deg	lb	lb	lb	lb	lb
2-STAGE LIMITED FREE LIFT	V270	107	82	81	4.7	4.7	8	10	7,716	7,716	7,716	7,716	13,016	13,358
	V300	119	88	87	4.7	4.7	8	10	7,716	7,716	7,716	7,716	13,082	13,424
	V330	131	94	93	4.7	4.7	8	10	7,716	7,716	7,716	7,716	13,166	13,508
	V350	139	100	99	4.7	4.7	8	10	7,716	7,716	7,716	7,716	13,217	13,558
	V370	146	104	103	4.7	4.7	8	10	7,716	7,716	7,716	7,716	13,261	13,603
	V400	158	112	111	4.7	4.7	8	10	7,716	7,716	7,496	7,606	13,353	13,695
	V430	170	118	117	4.7	4.7	8	10	7,716	7,716	7,385	7,496	13,420	13,761
	V450	178	122	121	4.7	4.7	8	6	7,716	7,716	7,275	7,385	13,603	13,944
2-STAGE FULL FREE LIFT	V500	198	132	131	4.7	4.7	8	6	7,496	7,716	7,055	7,165	13,715	14,057
	VF280	110	84	83	37	50	8	8	7,716	7,716	7,716	7,716	13,106	13,442
	VF300	118	88	87	41	53	8	8	7,716	7,716	7,716	7,716	13,164	13,499
3-STAGE FULL FREE LIFT	VF315	124	92	91	44	57	8	8	7,716	7,716	7,716	7,716	13,206	13,543
	TF/TS370	147	80	80	32	45	8	8	7,716	7,716	7,385	7,606	13,583	13,924
	TF/TS400	159	94	83	36	49	8	8	7,716	7,716	7,275	7,496	13,649	13,991
	TF/TS430	170	88	87	40	53	8	8	7,716	7,716	7,165	7,385	13,717	14,059
	TF/TS450	178	90	90	43	55	8	8	7,716	7,716	7,055	7,275	13,759	14,101
	TF/TS470	186	94	94	46	59	8	8	7,496	7,716	6,945	7,165	13,838	14,180
	TF/TS500	198	98	97	50	63	8	6	7,275	7,496	6,834	7,055	13,889	14,231
	TF/TS550	217	105	104	57	70	8	6	7,055	7,275	6,283	6,834	14,024	14,365
	TF/TS600	237	112	111	64	77	8	6	6,834	7,055	5,401	6,614	14,176	14,517
TF/TS650	257	119	119	71	84	8	6	6,614	6,614	5,181	6,393	14,266	14,608	

Mast Specification (40D-9)

Mast Type		Maximum Fork Height	Overall Height (Lowered)		Free Lift Height		Tilt Angle		Load Capacity Without Side Shift		Load Capacity With Side Shift		Truck Weight Unloaded	
			Single Tire	Double Tire	With Load Backrest	Without Load Backrest	Fwd	Rev	Single Tire	Double Tire	Single Tire	Double Tire	Single Tire	Double Tire
			in	in	in	in	in	deg	deg	lb	lb	lb	lb	lb
2-STAGE LIMITED FREE LIFT	V270	107	82	81	4.7	4.7	8	10	8,818	8,818	8,818	8,818	13,995	14,229
	V300	119	88	87	4.7	4.7	8	10	8,818	8,818	8,818	8,818	14,061	14,295
	V330	131	94	93	4.7	4.7	8	10	8,818	8,818	8,818	8,818	14,145	14,379
	V350	139	100	99	4.7	4.7	8	10	8,818	8,818	8,818	8,818	14,196	14,429
	V370	146	104	103	4.7	4.7	8	10	8,818	8,818	8,708	8,708	14,240	14,473
	V400	158	112	111	4.7	4.7	8	10	8,818	8,818	8,598	8,598	14,334	14,568
	V430	170	118	117	4.7	4.7	8	10	8,818	8,818	8,488	8,488	14,398	14,632
	V450	178	122	121	4.7	4.7	8	6	8,818	8,818	8,378	8,378	14,581	14,815
2-STAGE FULL FREE LIFT	V500	198	132	131	4.7	4.7	8	6	8,598	8,818	8,157	8,157	14,694	14,928
	VF280	110	84	83	36	49	8	8	8,818	8,818	8,818	8,818	14,085	14,312
	VF300	118	88	87	40	53	8	8	8,818	8,818	8,818	8,818	14,143	14,370
3-STAGE FULL FREE LIFT	VF315	124	92	91	44	56	8	8	8,818	8,818	8,818	8,818	14,185	14,412
	TF/TS370	147	80	80	32	45	8	8	8,818	8,818	8,598	8,708	14,562	14,718
	TF/TS400	159	94	83	36	49	8	8	8,818	8,818	8,488	8,488	14,628	14,784
	TF/TS430	170	88	87	40	53	8	8	8,818	8,818	8,378	8,378	14,696	14,852
	TF/TS450	178	90	90	42	54	8	8	8,818	8,818	8,378	8,378	14,738	14,894
	TF/TS470	186	94	94	46	58	8	8	8,818	8,818	8,157	8,267	14,817	14,974
	TF/TS500	198	98	97	49	62	8	6	8,598	8,598	7,937	8,047	14,868	15,025
	TF/TS550	217	105	104	57	69	8	6	8,157	8,378	7,385	7,717	15,002	15,159
	TF/TS600	237	112	111	64	77	8	6	7,937	7,937	6,504	7,496	15,155	15,331
TF/TS650	257	119	119	71	84	8	6	7,717	7,717	6,283	7,275	15,245	15,401	

Mast Specification (45D-9)

Mast Type		Maximum Fork Height	Overall Height (Lowered)		Free Lift Height		Tilt Angle		Load Capacity Without Side Shift		Load Capacity With Side Shift		Truck Weight Unloaded	
			Single Tire	Double Tire	With Load Backrest	Without Load Backrest	Fwd	Rev	24 in LC	24 in LC	24 in LC	24 in LC	Single Tire	Double Tire
			in	in	mm	mm	deg	deg	lb	lb	lb	lb	lb	lb
2-STAGE LIMITED FREE LIFT	V270	107	82	81	4.7	4.7	8	10	9,921	9,921	9,921	9,921	14,868	15,146
	V300	119	88	87	4.7	4.7	8	10	9,921	9,921	9,921	9,921	14,934	15,212
	V330	131	94	93	4.7	4.7	8	10	9,921	9,921	9,921	9,921	15,018	15,296
	V350	139	100	99	4.7	4.7	8	10	9,921	9,921	9,921	9,921	15,069	15,346
	V370	146	104	103	4.7	4.7	8	10	9,921	9,921	9,700	9,700	15,113	15,390
	V400	158	112	111	4.7	4.7	8	10	9,921	9,921	9,590	9,590	15,205	15,483
	V430	170	118	117	4.7	4.7	8	10	9,921	9,921	9,480	9,480	15,271	15,549
	V450	178	122	121	4.7	4.7	8	6	9,921	9,921	9,259	9,259	15,454	15,732
	V500	198	132	131	4.7	4.7	8	6	9,700	9,700	8,929	8,929	15,567	15,845
2-STAGE FULL FREE LIFT	VF280	110	84	83	34	67	8	8	9,921	9,921	9,921	9,921	14,947	15,225
	VF300	118	88	87	38	61	8	8	9,921	9,921	9,921	9,921	15,005	15,282
	VF315	124	92	91	41	63	8	8	9,921	9,921	9,921	9,921	15,047	15,324
3-STAGE FULL FREE LIFT	TF/TS370	147	80	80	31	44	8	8	9,921	9,921	9,590	9,590	15,435	15,717
	TF/TS400	159	94	83	35	48	8	8	9,921	9,921	9,480	9,480	15,501	15,783
	TF/TS430	170	88	87	39	52	8	8	9,921	9,921	9,259	9,259	15,569	15,851
	TF/TS450	178	90	90	42	54	8	8	9,921	9,921	9,149	9,149	15,611	15,893
	TF/TS470	186	94	94	45	58	8	8	9,700	9,700	9,039	9,039	15,690	15,975
	TF/TS500	198	98	97	49	62	8	6	9,480	9,480	8,818	8,818	15,741	16,025
	TF/TS550	217	105	104	56	69	8	6	9,259	9,259	8,488	8,488	15,878	16,160
	TF/TS600	237	112	111	63	76	8	6	8,818	8,818	7,165	8,267	16,028	16,310
	TF/TS650	257	119	119	70	83	8	6	8,598	8,598	6,945	8,047	16,120	16,402

Mast Specification (50D-9)

Mast Type		Maximum Fork Height	Overall Height (Lowered)		Free Lift Height		Tilt Angle		Load Capacity Without Side Shift		Load Capacity With Side Shift		Truck Weight Unloaded		
			Single Tire	Double Tire	With Load Backrest	Without Load Backrest	Fwd	Rev	24 in LC	24 in LC	24 in LC	24 in LC	Single Tire	Double Tire	
			mm	in	in	mm	mm	deg	deg	lb	lb	lb	lb	lb	lb
2-STAGE LIMITED FREE LIFT	V260	2630	82	81	4.7	4.7	8	10	11,023	11,023	11,023	11,023	15,820	16,074	
	V290	2930	88	87	4.7	4.7	8	10	11,023	11,023	11,023	11,023	15,875	16,131	
	V320	3230	94	93	4.7	4.7	8	10	11,023	11,023	11,023	11,023	15,931	16,186	
	V340	3430	100	99	4.7	4.7	8	10	11,023	11,023	10,913	10,913	15,986	16,239	
	V360	3630	104	103	4.7	4.7	8	10	11,023	11,023	10,803	10,803	16,021	16,277	
	V390	3930	112	111	4.7	4.7	8	10	11,023	11,023	10,582	10,582	16,100	16,354	
	V440	4430	122	121	4.7	4.7	8	6	10,803	11,023	10,252	10,252	16,327	16,583	
	V490	4930	132	131	4.7	4.7	8	6	10,582	10,803	9,921	9,921	16,420	16,676	
2-STAGE FULL FREE LIFT	VF270	2702	84	83	36	48	8	8	11,023	11,023	10,362	10,472	15,950	16,197	
	VF290	2902	88	87	40	52	8	8	11,023	11,023	10,252	10,362	16,006	16,252	
	VF305	3052	92	91	43	56	8	8	11,023	11,023	10,031	10,141	16,045	16,292	
3-STAGE FULL FREE LIFT	TF/TS360	3672	80	80	32	42	8	8	11,023	11,023	10,362	10,582	16,356	16,585	
	TF/TS390	3972	94	83	36	46	8	8	11,023	11,023	10,252	10,362	16,413	16,643	
	TF/TS420	4272	88	87	40	50	8	8	10,803	11,023	10,031	10,141	16,469	16,698	
	TF/TS440	4452	90	90	42	53	8	8	10,582	11,023	9,921	10,031	16,506	16,733	
	TF/TS460	4662	94	94	46	56	8	8	10,362	10,803	9,811	9,921	16,557	16,786	
	TF/TS490	4962	98	97	49	60	8	6	10,141	10,582	9,590	9,811	16,612	16,841	
	TF/TS540	5462	105	104	57	67	8	6	9,921	10,362	9,370	9,480	16,726	16,956	
	TF/TS590	5972	112	111	64	74	8	6	9,700	10,141	9,039	9,259	16,817	17,044	
	TF/TS640	6482	119	119	71	81	8	6	9,480	9,921	8,818	9,039	16,907	17,137	

New 9 Series

Dimensions

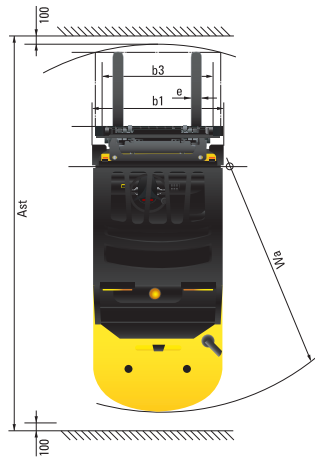
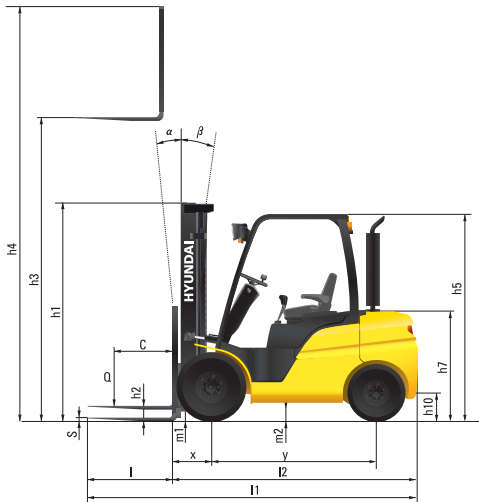

Specifications

Identification						
1.1	Manufacturer		Hyundai	Hyundai	Hyundai	Hyundai
1.2	Manufacturer's model designation		35D-9	40D-9	45D-9	50DA-9
1.3	Drive: electric (battery or mains), diesel, petrol, fuel gas, manual		Diesel	Diesel	Diesel	Diesel
1.4	Type of operation: hand, pedestrian, standing, seated, order-picker		Seated	Seated	Seated	Seated
1.5	Load capacity / Rated load	lb	7,700	8,800	9,900	11,000
1.6	Load center distance	c in	24	24	24	24
1.8	Load distance, center of drive axle to fork	x in	22	22	22	23
1.9	Wheelbase	y in	79	79	79	79

Weights						
2.1	Service weight	lb	13,082	14,295	15,212	16,131
2.2	Axle loading, loaded front / rear	lb	17,948 / 2,851	20,078 / 3,034	21,806 / 3,327	23,541 / 3,611
2.3	Axle loading, unloaded front / rear	lb	5,756 / 7,326	6,144 / 8,148	6,131 / 9,081	6,124 / 10,005

Wheels, Chassis						
3.1	Tires ; Pneumatic (P), Solid (S), Non-marking (N)		P	P	P	P
3.2	Tires size, front		8.25 x 15-14PR	7.50 x 16-12PR	7.50 x 16-12PR	7.50 x 16-12PR
3.3	Tires size, rear		7.00 x 12-12PR	7.00 x 12-12PR	7.00 x 12-14PR	7.00 x 12-14PR
3.4	Number of wheels front / rear (x = driven wheels)		2 x 2	4 x 2	4 x 2	4 x 2
3.5	Track width, front	in	45	50	50	50
3.6	Track width, rear	in	45	45	45	45

Basic Dimensions						
4.1	Mast / fork carriage tilt forward / backward (α / β)	degrees	8 / 10	8 / 10	8 / 10	8 / 10
4.2	Lowered mast height	h1 (in)	88	87	87	87
4.3	Free lift	h2 (in)	4.7	4.7	4.7	4.7
4.4	Lift height	h3 (in)	119	119	119	115
4.5	Extended mast height	h4 (in)	167	167	167	163
4.7	Overhead guard height (cabin)	h5 (in)	87 (93)	87 (93)	87 (93)	87 (93)
4.8	Seat height / standing height rel. to SIP	h7 (in)	42	42	42	42
4.12	Coupling height	h10 (in)	14	14	14	14
4.19	Overall length	l1 (in)	169	169	177	177
4.20	Length to face of forks	l2 (in)	127	127	129	130
4.21	Overall width	b1 (in)	54	69	69	69
4.22	Fork dimensions (hook type)	l / e / s (in)	42 x 4.8 x 2.0	42 x 5.9 x 2.0	48 x 5.9 x 2.0	48 x 5.9 x 2.4
4.23	Fork carriage ISO 2328, class / type A,B		III / A	III / A	IV / A	IV / A
4.24	Fork carriage width	b3 (in)	51	63	63	63
4.31	Ground clearance, loaded, under mast	m1 (in)	6.7	6.1	6.1	6.1
4.32	Ground clearance, centre of wheelbase	m2 (in)	7.9	7.3	7.3	7.3
4.33	Aisle width for pallets 40 x 48 crossways (L x W)	Ast (in)	185	185	187	188
4.34	Aisle width for pallets 32 x 48 lengthways (W x L)	Ast (in)	193	193	195	196
4.35	Turning radius	Wa (in)	116	116	118	118
4.36	Smallest pivot point distance	in	40	40	40	40

Performance Data						
5.1	Travel speed, unloaded	mph	16.5	16.0	15.9	15.9
5.2	Lift speed, loaded / unloaded	ft / min	100 / 106	98 / 106	96 / 106	83 / 91
5.3	Lowering speed, loaded / unloaded	ft / min	98 / 98	98 / 98	98 / 98	98 / 98
5.5	Drawbar pull, loaded	lb	8,752	8,805	8,818	8,832
5.7	Gradient performance, loaded	%	40.9	36.4	33.2	30.6
5.9	Acceleration time, loaded / unloaded (10m)	sec	-	-	-	-
5.10	Service brake		Foot	Foot	Foot	Foot

Engine						
6.1	Engine manufacturer / type		CUMMINS QSF3.8	CUMMINS QSF3.8	CUMMINS QSF3.8	CUMMINS QSF3.8
6.2	Engine power acc. to ISO 1585	hp / rpm	101 / 2,200	101 / 2,200	101 / 2,200	101 / 2,200
6.3	Maximum Torque	lbf.ft / rpm	306 / 1,600	306 / 1,600	306 / 1,600	306 / 1,600
6.4	No. of cylinders / cubic capacity	EA / cc	4 / 3,726	4 / 3,726	4 / 3,726	4 / 3,726
6.5	Fuel consumption acc. To VDI cycle	ℓ/h	6.1	6.2	6.4	6.5

Other Details						
8.1	Type of drive control		Power shift 2/2	Power shift 2/2	Power shift 2/2	Power shift 2/2
8.2	Operating pressure, system / attach	lbf / in ²	463 / 23	463 / 23	463 / 23	463 / 23
8.3	Oil volume for attachment	ℓ	100	100	100	100

35/40/45D-9 50DA-9

Load capacity

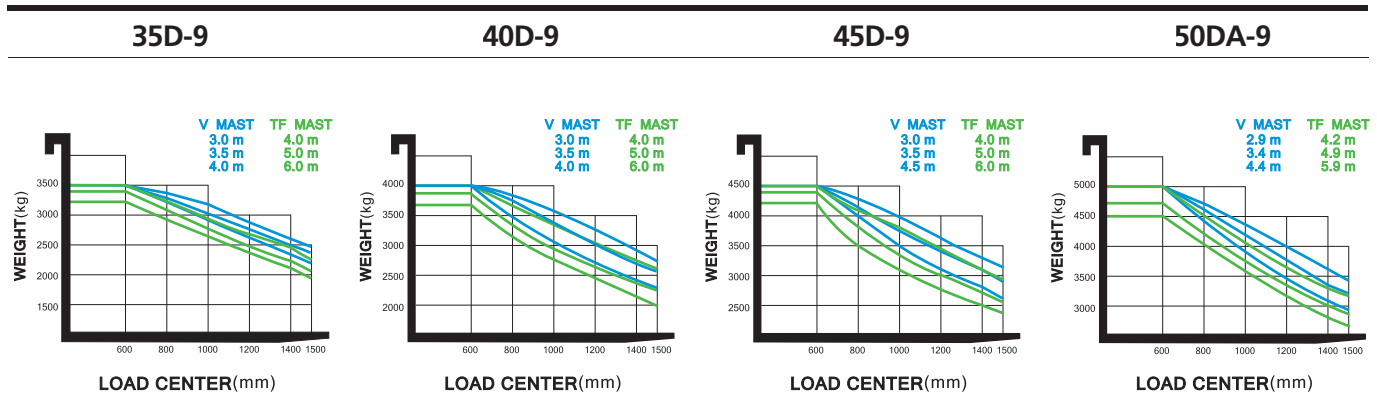

Attachments

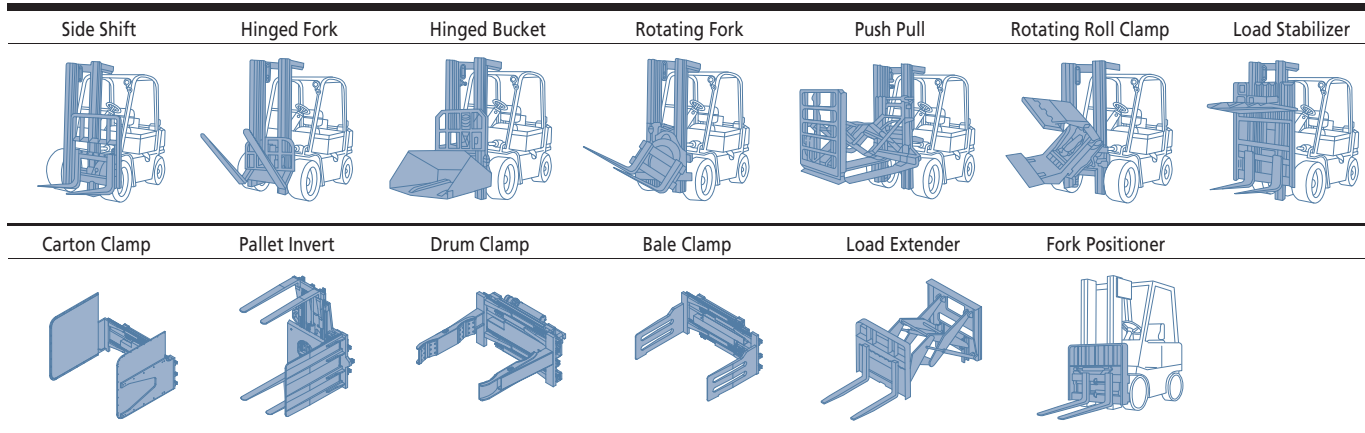

Optional items

- Fork (in)
 - 30/40D-9: 42 (standard), 48, 54, 60, 66, 72, 78, 83, 94
 - 45D-9: 42, 48 (standard), 54, 60, 66, 72, 78, 83, 94
 - 50DA-9: 47, 53, 59, 71, 79, 94
- Overshoe (in)
 - 30D-9: 63, 71, 79
 - 40/45D-9: 71, 79, 87
 - 50DA-9: 71, 79, 87, 91
- Integral sideshift, fork positioner, sideshift, INT, SS with FP for single tire
- Tire: Solid (superelastic) / non-marking / front single / double tire
- M.C.V: 3-spool, 4-spool, 5-spool
- Seat: Armrest, Heat, Backrest Ext, Buckle SW
- Load weight indicator
- Auto fork leveling system
- Rear-view camera
- Cabin (heater and air conditioner)
- Hydraulic pump temperature / pressure monitor
- Battery disconnect switch (master switch)
- Beacon lamp (LED) (amber, red, blue)
- Rear work lamp or LED rear work lamp
- F-N-R and horn knob switch
- Rear horn
- LED work lamp
- Overhead guard (height: 92 inches / 2340 mm)
- OPPS (Travel, Travel Mast)



www.hceamericas.com
Hyundai Construction Equipment Americas, Inc.
6100 ATLANTIC BOULEVARD NORCROSS GA 30071 U.S.A
TEL (678) 823-7777 / FAX (678) 823-7778